

3

Contactors

C300 series

1 pole
bi-directional DC
NO contactors
up to 500 amps

Catalogue C300.en

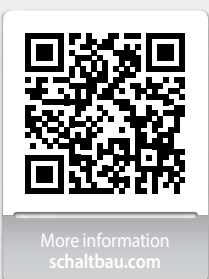
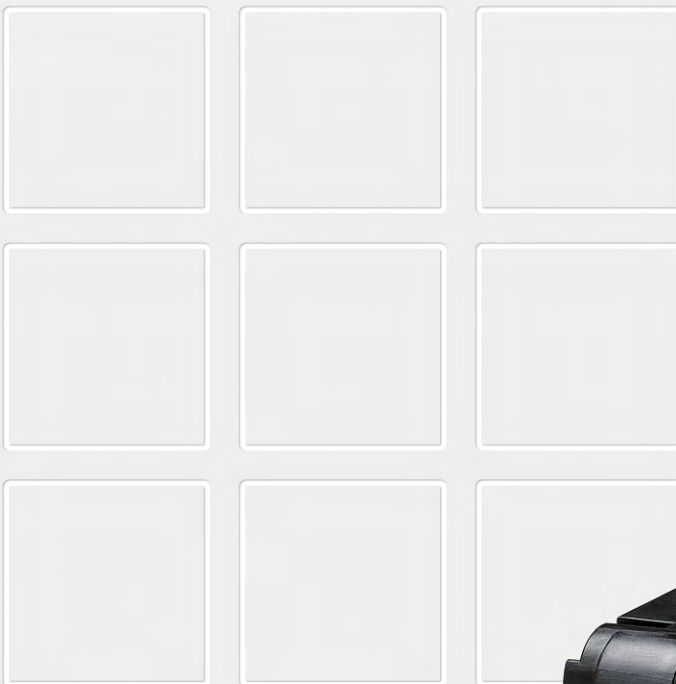

More information
schaltbau.com

C300 – 1 pole bi-directional DC NO contactors

Compact single-pole NO contactors for AC and DC up to 1,500 V rated insulation voltage. Making current up to 6,000 amps; conventional thermal current up to 500 amps; short-time current up to 6,000 amps.

The bi-directional DC contactors C300 switch high power in the smallest space. With a making capacity of up to 6,000 amperes, the extremely compact series is suitable for applications with high inrush currents or high capacitances.

All versions can carry up to 500 amperes continuously. In the event of a short circuit, even 6,000 amperes may flow for 20 milliseconds without the contacts welding.

This means that the contactor retains its full function to separate large powers when required: up to 500 amperes and up to 1,500 volts – regardless of the direction of the current. This full bi-directionality is important for systems with a charging and discharging process, such as in battery storage or electric vehicles. Other typical applications are the DC circuit in inverters, combiner boxes in photovoltaic systems or the management of battery storage systems.

Features

C300 series

Super-compact dimensions – high rated insulation voltage U_i up to 1,500 volts
Smallest dimensions – great performance! Nevertheless, all the air gaps in the contact area have been generously dimensioned. The rated insulation voltage is 1,500 volts.
The arc chamber of the C300 is made of plastic. This is efficient and saves weight.

High short-time withstand current rating I_{cw} of up to 6,000 amps
For 20 milliseconds, the C300 can carry a current of up to 6,000 amps without the contacts welding. This time is sufficient for the short-circuit protection to trip. The short-time current carrying capacity is supported by high contact forces and an optimised contact geometry.

High thermal continuous current I_{th} of up to 500 amps
All versions of the C300 can permanently carry up to 500 amps – provided a sufficiently dimensioned connection cross-section of 300 mm². The maximum ambient temperature for industrial applications is 85 °C. These excellent values are achieved through very high contact forces.

Full bi-directionality – reliable disconnection of high performances
All versions of the C300 can reliably separate high currents and voltages when required, regardless of the direction of the current. These properties are achieved by the special arrangement of blowout magnets and arc chamber, burn-off resistant silver contacts, high contact forces and generously dimensioned air gaps in the contact area.

High making capacity I_{cm} of up to 6,000 amps
The C300 can switch on a current of up to 6,000 amps. High contact forces and burn-off resistant silver contacts favour the excellent breaking capacity.
An integrated PWM controller regulates the coil current for all operating states, ensures low-bounce switching on and optimises the holding power.

Auxiliary switch with mirror contact function
The C300 contactors have an integrated auxiliary contact with mirror contact function according to IEC 60947-4-1, annex F. Mirror contacts are required in feedback circuits of safety controls. The mirror contact function informs about the switching state and ensures that the NC contact of the auxiliary contact is not closed at the same time as the NO main contact.

Standards

C300 series

IEC 60947-4-1
Low-voltage switchgear and controlgear – Part 4-1: Contactors and motor starters – Electromechanical contactors and motor starters.

UL 60947-4-1
Low-Voltage Switchgear and Controlgear – Part 4-1: Contactors and Motor-Starters – Electromechanical Contactors and Motor-Starters.

ISO 16750-3
Road vehicles – Environmental conditions and testing for electrical and electronic equipment – Part 3: Mechanical loads

GB/T 14048.4 (in preparation)
Low-Voltage Switchgear and Controlgear – Part 4-1: Contactors and Motor-Starters – Electromechanical Contactors and Motor-Starters.

Reliable, robust and economical

C300 series

Contactors of the C300 series are designed for continuous currents of 500 amps. The switchgear has both high making and breaking capacities, and a high short-time withstand current. This ensures high operational safety.

An integrated electronic coil control ensures a constant and reliable switching behaviour independent of the ambient temperature. In addition, the energy consumption and associated heat development of the monostable design is noticeably reduced when switched on.

Dependent on the application, high requirements can be placed on electromechanical components. The new DC contactors are highly resistant to shock and vibration loads and meet the high requirements of ISO 16750.

Ordering key

C300 series

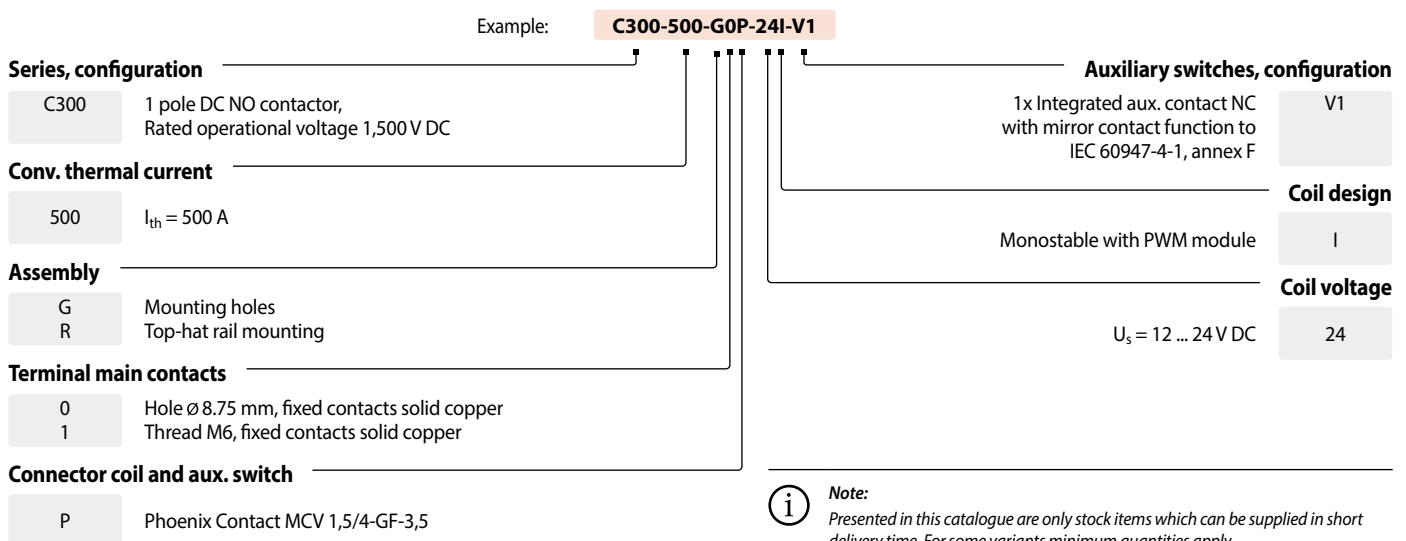

Accessories

Connector for connecting coil and auxiliary switch

4-pole PCB connector FMC 1,5/4-STF-3,5
Phoenix Part-No. 1966114, can be ordered separately

Application

C300 series

Due to many years of experience and expertise in the development of electromechanical switchgear and the control of DC arcs Schaltbau

The compact switching device can be integrated especially in areas where there is no space for larger series. Since the C300 series can reliably switch in both directions of current, it is ideally suited for applications with energy recovery. In battery-powered and hybrid vehicles, the units can be used as main contactors directly in the Battery Disconnect Unit (BDU). Here, the C300 reliably ensures the galvanic isolation of both poles of the battery

has developed an innovative solution with the new compact contactors that further simplify applications in DC switching technology.

from the vehicle's powertrain in the event of a fault. Other areas of application for the C300 series are regenerative systems and DC charging stations or battery test benches. A further application for the use of bi-directional contactors of the C300 series are stationary energy storages. Batteries are charged and discharged regularly. For this purpose it is important that the contactors can switch off safely in both current directions.



E-mobility:

- Main contactor in electric vehicles, vehicles with hybrid drives and electric buses
- DC fast charging stations
- Battery test benches for the automotive industry



Stationary applications:

- Grid stabilization and battery energy storage
- Regenerative systems in industrial plants
- Battery management systems
- Photovoltaics and UPS

Dimension diagram C300-500-G1P-xxl-V1, C300-500-R0P-xxl-V1

C300 series

• **C300-500-G1P-xxl-V1: Version with PWM module, for screw mounting**

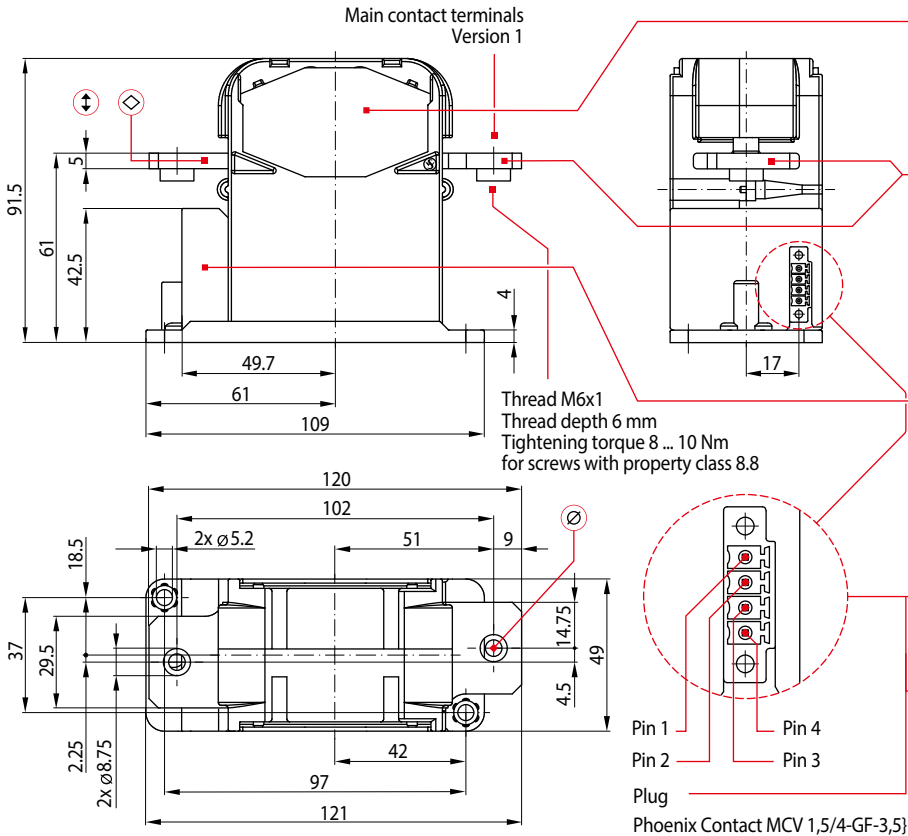

Arc chamber main contact system

- Massive designed 1-pole contact system
- Highly efficient plastic arc chamber with permanent magnetic blowing

Main contact terminals

- ◇ Material: Copper
- ⊕ Thickness: 5 mm
- ⊙ Version 0: Hole Ø 8.75 mm
Version 1: Thread M6x1

Electronic coil controller

Permanently reliable switching behaviour regardless of ambient temperature, reduced energy consumption and less heat generation.

Coil terminal

- Pin 1: Coil, terminal 1: +U_s
- Pin 2: Coil, terminal 2: -U_s

Auxiliary switch

- V1: 1x NC with mirror contact function
- Pin 3: NC contact, terminal 1
- Pin 4: NC contact, terminal 2



A connector FMC 1,5/4-STF-3,5 (Phoenix Part-No. 1966114) is required to connect the coil and the auxiliary switch.

• **C300-500-R0P-xxl-V1: Version with PWM module, for top-hat rail mounting**

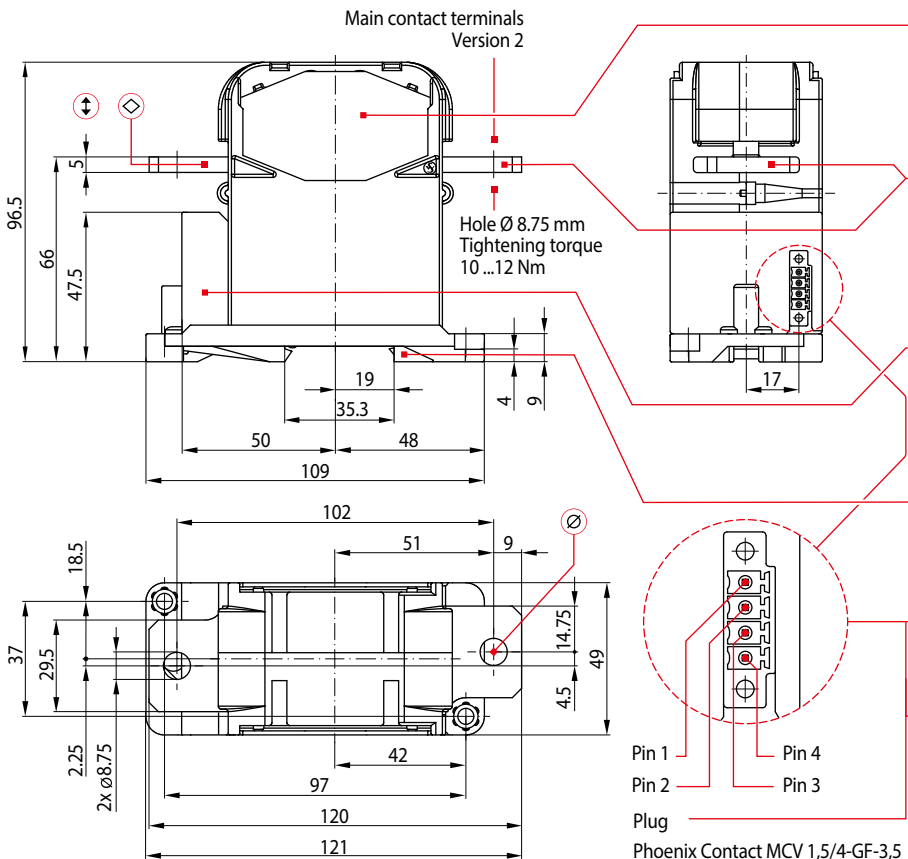

Arc chamber main contact system

- Massive designed 1-pole contact system
- Highly efficient plastic arc chamber with permanent magnetic blowing

Main contact terminals

- ◇ Material: Copper
- ⊕ Thickness: 5 mm
- ⊙ Version 0: Hole Ø 8.75 mm
Version 1: Thread M6x1

Electronic coil controller

Permanently reliable switching behaviour regardless of ambient temperature, reduced energy consumption and less heat generation.

Top-hat rail mounting

Mounting on mounting rail NS 35/15 according to IEC 60715

Coil terminal

- Pin 1: Coil, terminal 1: +U_s
- Pin 2: Coil, terminal 2: -U_s

Auxiliary switch

- V1: 1x NC with mirror contact function
- Pin 3: NC contact, terminal 1
- Pin 4: NC contact, terminal 2



A connector FMC 1,5/4-STF-3,5 (Phoenix Part-No. 1966114) is required to connect the coil and the auxiliary switch.

Circuit diagram, connection

C300 series

• Circuit diagram, version with PWM module

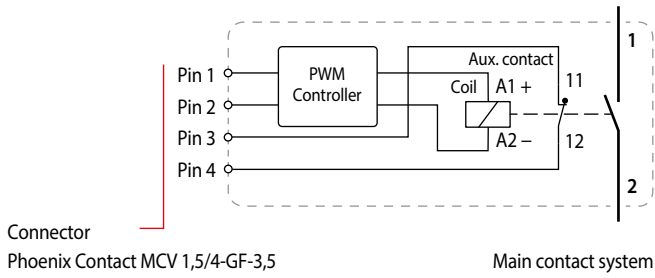

• 4-pole connector for connecting of coil and auxiliary switch

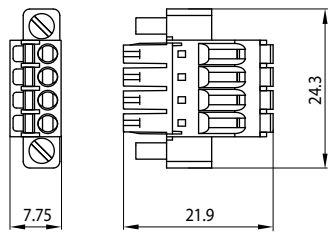

4-pole PCB connector
FMC 1,5/4-STF-3,5

- Cross-section: 1.5 mm² max.
- Connection: Push-in spring connection
- Locking: Screw locking

• Contact assignment

Terminal	Contact	Description
Main contacts	1	Main contact 1
	2	Main contact 2
Coil contacts	Pin 1	Coil A1+ U _s +
	Pin 2	Coil A2- U _s -
Aux contacts	Pin 3	Contact 11
	Pin 4	Contact 12

} Fixed contact, solid copper

} Connector Phoenix Contact MCV 1,5/4-GF-3,5

• Contact assignment

Terminal	Contact	Description
Coil contacts	Pin 1	Coil A1+ U _s +
	Pin 2	Coil A2- U _s -
Aux contacts	Pin 3	Contact 11
	Pin 4	Contact 12

} Connector Phoenix Contact FMC 1,5/4-STF-3,5

Permissible mounting orientations

C300 series

• C300-500-G0P-xxl-V1: Screw mounting version

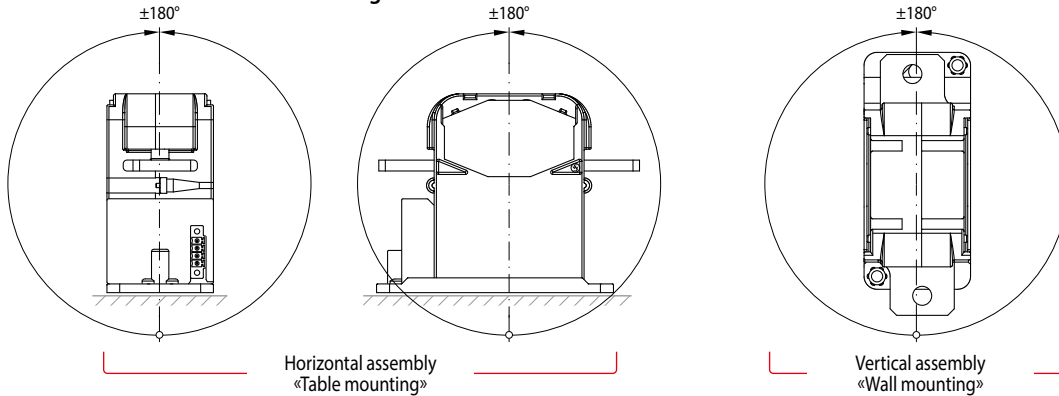

• C300-500-R0P-xxl-V1: Version for top-hat rail mounting

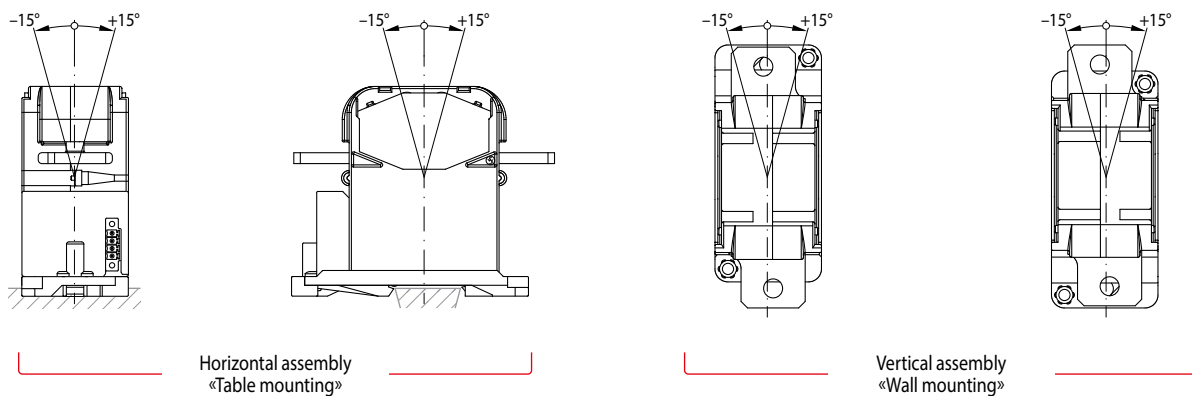

Mounting holes

C300 series

• Mounting holes

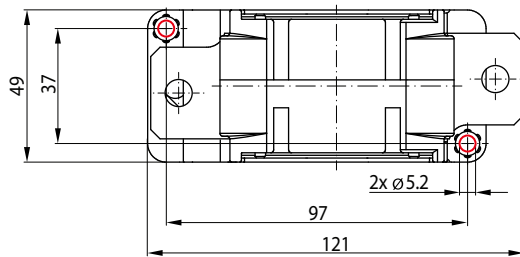

The contactors with mounting type "G" are mounted on a suitable mounting plate with two M5 screws.

Tightening torque:

5 ... 6 Nm for screws with property class 8.8

Maintenance and safety instructions

C300 series

Maintenance:

- C300 series contactors are basically maintenance free.
- Make regular in-depth visual inspections once or twice a year.

Safety instructions:

- The device must be used according to the intended purpose as specified in the technical documentation. You are obliged to observe all specifications depending on operating temperature, degree of pollution etc. that are relevant to your application.
- Without further safety measures the contactors are not suited for use in potentially explosive atmospheres.
- In case of malfunction of the device or uncertainties stop using it any longer and contact the manufacturer instantly.
- Tampering with the device can seriously affect the safety of people and equipment. This is not permitted and leads to an exclusion of liability and warranty.
- Coil suppression for reducing surges when the coil is switched off is optimally attuned to the contactors switching behaviour. The existing opening characteristic must not be negatively influenced by parallel connection with an external diode.
- Contactors running permanently may heat up. So make sure that the contactor has sufficiently cooled down before you start any inspection or maintenance work.



For detailed maintenance, safety and mounting instructions please refer to our operating manuals
 ➔ [C300-M.en!](#)

- When installing contactors with magnetic blowout make sure to do it in such a way that no magnetizable parts can be attracted by the permanent magnets that are also capable of destroying all data of swipe cards.
- In general, strong electromagnetic fields can be generated in the area around the contactors. These can influence other components in the area of the contactors.
- Improper handling of the contactor, e.g. when hitting the floor with some impact, can result in breakage, visible cracks and deformation.



Defective contactors must be replaced immediately!



For a detailed list of all safety instructions see here:
 ➔ schaltbau.info/safety3en!

Schaltbau GmbH

For detailed information on our products and services visit our website – or give us a call!

Schaltbau GmbH
Hollerithstrasse 5
81829 Munich
Germany



Phone +49 89 9 30 05-0
Fax +49 89 9 30 05-350
Internet www.schaltbau.com
e-Mail contact@schaltbau.de



The production facilities of Schaltbau GmbH have been IRIS certified since 2008.



Certified to DIN EN ISO 14001 since 2002. For the most recent certificate visit our website.



Certified to DIN EN ISO 9001 since 1994. For the most recent certificate visit our website.

Electrical Components and Systems for Railway Engineering and Industrial Applications

Connectors

- Connectors manufactured to industry standards
- Connectors to suit the special requirements of communications engineering (MIL connectors)
- Charging connectors for battery-powered machines and systems
- Connectors for railway engineering, including UIC connectors
- Special connectors to suit customer requirements

Snap-action switches

- Snap-action switches with positive opening operation
- Snap-action switches with self-cleaning contacts
- Snap-action switch made of robust polyetherimide (PEI)
- Snap-action switch with two galvanically isolated contact bridges
- Special switches to suit customer requirements

Contactors Emergency disconnect switches

- Single and multi-pole DC contactors
- High-voltage AC/DC contactors
- Contactors for battery powered vehicles and power supplies
- Contactors for railway applications
- Terminal bolts and fuse holders
- DC emergency disconnect switches
- Special contactors to suit customer requirements

Electrics for rolling stock

- Equipment for driver's cab
- Equipment for passenger use
- High-voltage switchgear
- High-voltage heaters
- High-voltage roof equipment
- Equipment for electric brakes
- Design and engineering of train electrics to customer requirements

with compliments: